



Integrated Engineering Services



Specialist High Integrity HVAC Services

Engineering a Better Environment



# Integrated Engineering Services

## *The Beginning*

As early as 1984, IES Ltd (Aberdeen) have been at the forefront of providing dedicated specialist HVAC services to the UK's Energy industries.

From custom built facilities in Aberdeen, the company's early experience has been gained in the demanding sector

## *HVAC: Main Industries*

- Oil & Gas and Petrochemical
- Energy & Utilities
- Pharmaceuticals & Chemicals
- Semi-conductors
- Industrial & Manufacturing
- Food & Drink
- Commercial, Retail & Leisure



of the Offshore Oil & Gas industry; focusing initially on the design and asset management of Process and safety critical HVAC systems.

## *The Present*

Today, with a core staff of some 50 HVAC Engineers, CAD operators and Service Technicians, IES Ltd is one of the largest independent companies in this specialist field. Built on its reputation for quality and value, the company has developed a full portfolio of services ranging from HVAC Design, Build and Commission through to Total Facilities Management, Maintenance Management and Systems Hygiene.

## *The Future*

IES Ltd have invested heavily in the future in terms of training, new facilities and service innovation. In particular, the company recognise that their people are their greatest asset. It is perhaps a staggering thought to realise that IES Ltd can draw on a collective HVAC experience of several hundred years!

From such a solid grounding, the Company looks forward to the future and in continuing to develop their speciality skills and services.

## *HVAC Services Overview*

Built on an experience of high integrity HVAC systems, IES Ltd has developed a comprehensive structure of services to meet rigorous legislative and process demands:

- ① HVAC Consultancy, Design & CAD
- ② Procurement & Installation
- ③ Commissioning
- ④ Refrigeration
- ⑤ Maintenance & Servicing
- ⑥ Total Asset & Facilities Management
- ⑦ HVAC Hygiene & Cleaning
- ⑧ COSHH LEV Inspection & Testing
- ⑨ Fire Rated Doors & Partitioning
- ⑩ Environment

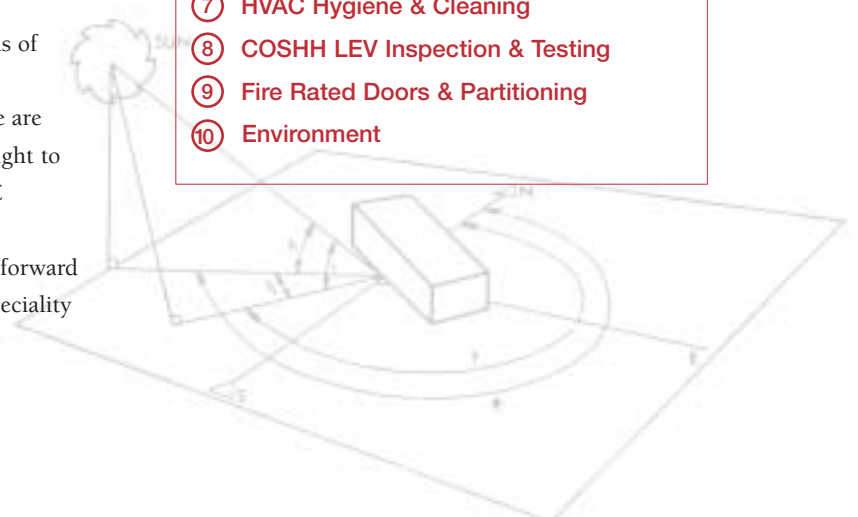



## 2 *Procurement & Installation*

Extensive supply chain links and successful track record of on time, on budget EPIC and Turnkey contracts

## 3 *Commissioning*

Wide International experience of commissioning M&E Building Services, HVAC, Refrigeration, Gas and associated plant controls systems.



## 1 *HVAC Design, Consultancy & CAD*

Full compliment of Consultants, Design Engineers and CAD Operators experienced in the following:

- New Systems designs & modification
- Conceptual & front end Design
- Legislative specification
- Technical Reports & Manuals
- Project Management
- CAD Drafting
- Design Survey & Audit
- Systems & Plant Review
- Quality & Environmental Management
- Certification & Documentation
- Systems Troubleshooting
- Health & Safety

## 4 *Refrigeration*

IES Ltd offer a comprehensive refrigeration service and ensures compliance with the latest environmental standards:

- Refrigerant CFC recovery
- Refrigerant change-out and conversion
- Industrial & Commercial Equipment
- Servicing & Maintenance

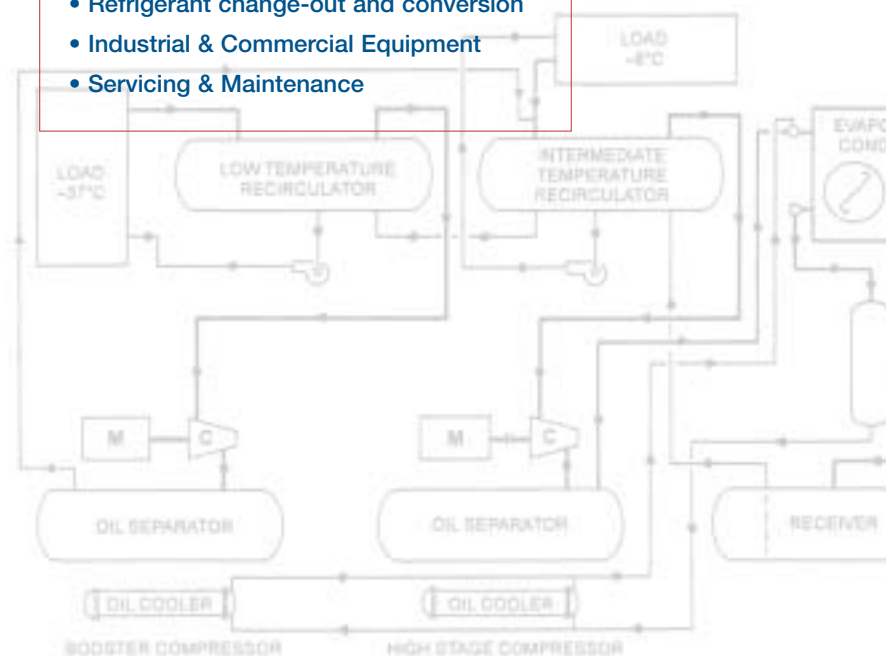



BS EN ISO 9001

5

### *Maintenance & Servicing*

IES Ltd are among the market leaders in providing cost effective specialist HVAC Maintenance and Servicing regimes tailored to suit each individual client's requirements. The specific service may be drawn from any of the following:



- Specialist skilled personnel
- Client personnel on site training
- Planned Preventive Maintenance (PPM)
- Planned Maintenance Routines (PMR)
- Reliability Centred Maintenance (RCM)
- Condition Based Maintenance (CBM)
- Vibration Analysis
- Maintenance Strategy Study
- Procedural Implementation
- Life Cycle cost management
- Spares Management

6

### *Total Asset & Facilities Management*

Embodying all of the above, IES Ltd are engaged on a number of client partnership contracts whereby full responsibilities for operation and maintenance are borne by the HVAC Custodian. Adherence to key performance indicators may form the contractual basis:

- Systems performance & Availability
- Statutory Compliance
- Servicing & Repair response
- Health & Safety and HR management
- Quality & Environment

Systems deemed to be of a critical nature for safety or production can be continually monitored via remote telemetry to our Aberdeen office.

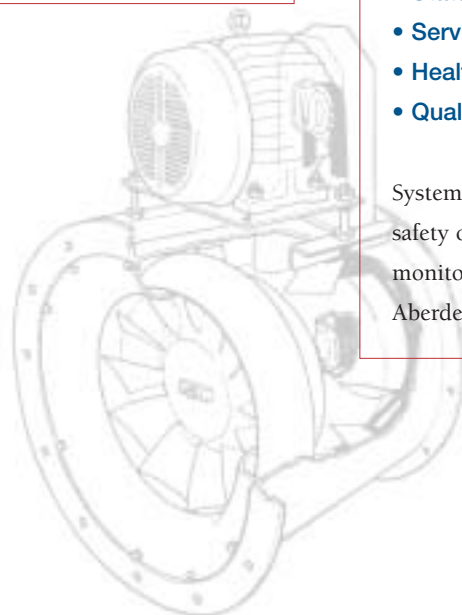

7

### ***HVAC Hygiene & Cleaning***

Revolutionary & patented ductwork cleaning system utilising a compressed air projectile head to remove all forms of bacteria, fungi and debris accumulated within the ductwork & ventilation system.

Cleaning range of 30 metres from entry point ensures minimum disruption to business



9

### ***Fire Rated Doors & Partitions***

By forging strong links with some of the industry's best regarded companies, I.E.S. Ltd are authorised to design, supply and maintain an extensive range of fire rated products:

- Fire doors and Blast doors
- Heavy duty door furniture
- Water & Gas tight doors
- Firewalls & Blastwalls
- Blast relief systems
- Radiant Heat shields
- Modular Habitats
- Acoustic Enclosures

services. 75% quicker than conventional methods with virtually no need for post room cleaning.

- Patented Duct cleaning system
- Mandatory annual inspections
- Deep clean & disinfection
- CO<sub>2</sub> Degreasing
- Video surveys
- Hospital hygiene & clean rooms
- Certification of cleanliness

8

### ***COSHH LEV Inspection & Testing***

Engineers & Technicians fully trained in the latest applications of Industrial Hygiene Ventilation:

- COSHH Assessments
- L.E.V. Examination, Inspection & Testing
- Fume & containment cupboards
- Portable Fume Extraction systems
- Air Cleaners & Scrubbers

10

### ***Environment***

Full range of Building Environmental Services, including:

- Noise control & acoustics
- Sick-building analysis
- Water treatment
- Bacterial analysis
- Air Quality Measurement
- H.S & E. Management





## Integrated Engineering Services

Integrated Engineering Services (Aberdeen) Ltd.,  
Lomond House, Wellington Circle, Redmoss, Aberdeen AB12 3JG

Tel: 01224 894222 Fax: 01224 899822

Email: [sales@ies-ltd.co.uk](mailto:sales@ies-ltd.co.uk)

[www.ies-ltd.co.uk](http://www.ies-ltd.co.uk)



Associate Member



Certificate No FS 45610  
BS EN ISO 9001